

IMP E P - IMP T P Warning Colour

Soap-/disinfectant dispenser for disposable bottles as well as refillable containers and hygiene packages, aluminium housing, powder-coated warning colours, short operating lever, 500 ml or 1000 ml

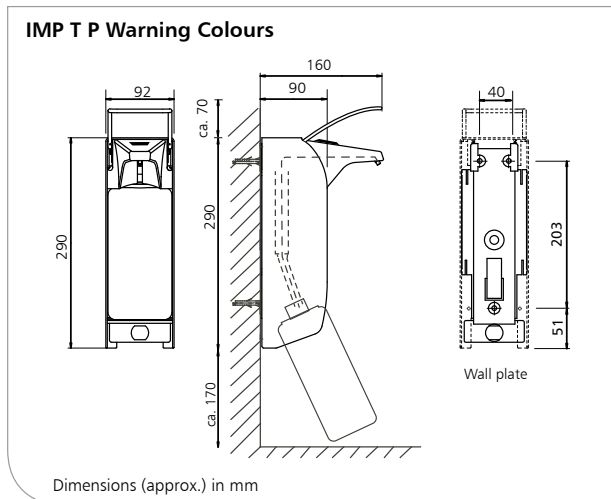
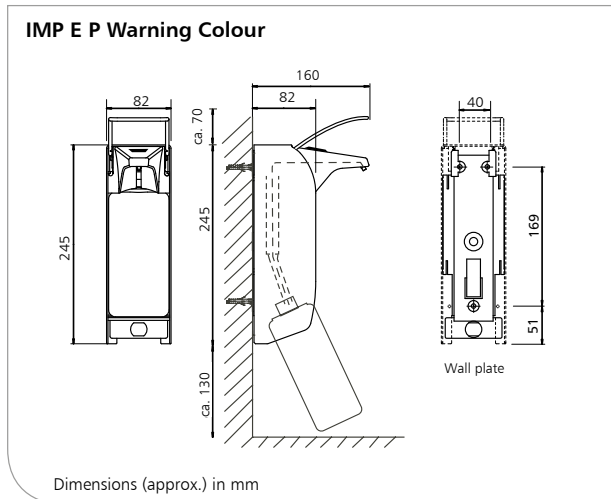

Product characteristics

- ▶ Dispenser for liquid soaps without grit, alcoholic hand disinfectants, lotion, massage oil, etc.
- ▶ For 500 ml or 1000 ml disposable bottles as well as refillable containers and hygiene packages
- ▶ With replaceable pump
- ▶ Pivoting face shield for simple pump replacement from the front without having to remove the dispenser from the wall
- ▶ In warning colour
- ▶ Incl. mounting kit for three-point wall mounting

Interesting information

References:

- ▶ Clinics, doctors' practices, health and care facilities, laboratories, rescue stations, commercial kitchens, foodstuffs industry, commercial and industrial operations

Application examples:

- ▶ Particularly well suited to areas where hand hygiene is critical and in medical and food processing areas

Technical data

- Housing: Powder-coated aluminium
- Dosing pump: IMP 24 series stainless steel pump, standard pump, angled stainless steel suction tube, autoclavable, stainless steel pump cylinder
- Dispensing quantity: Dispensing quantity adjustable to ca. 0.75 ml/1.0 ml/1.2 ml/1.5 ml (depending on the viscosity of the filling material)
- Operating lever: Stainless steel
- Wall plate: Standard ingo-man® plastic wall plate
- Wall mounting: Wall mounting with 3 screws and wall plugs
- Cleaning: Dispenser dishwasher-safe, not autoclavable, standard pump dishwasher-safe and autoclavable up to 134° C, 2 bar

Description for tender - see overleaf

IMP E P - IMP T P Warning Colour
1216/1.0



Subject to technical modifications.
Tests are required before new filling materials are used!



OPHARDT Hygiene-Technik GmbH + Co. KG
Lindenau 27 | 47661 Issum | Germany
Tel.: +49 2835 18-10 | Fax: +49 2835 18-77
www.ophardt.com | E-Mail: planer@ophardt.com

IMP E P - IMP T P Warning Colour

Soap-/disinfectant dispenser for disposable bottles as well as refillable containers and hygiene packages, aluminium housing, powder-coated warning colours, short operating lever, 500 ml or 1000 ml

Description for tender

... Pcs.	ingo-man® plus IMP E P/24 luminous red Art. No. 1418091 Soap-/disinfectant dispenser, 500 ml, suitable for standard disposable bottles, refillable containers and hygiene packages, luminous red powder-coated aluminium housing, short stainless steel operating lever, with identification clip, incl. empty bottle, replaceable IMP 24 series stainless steel pump, easy pump replacement through front removal, autoclavable and dishwasher-safe Dimensions: W 82 x H 245 x D 160 mm	... Pcs.	ingo-man® plus IMP E P/24 luminous bright orange Art. No. 1418093 Soap-/disinfectant dispenser, 500 ml, suitable for standard disposable bottles, refillable containers and hygiene packages, luminous bright orange powder-coated aluminium housing, short stainless steel operating lever, with identification clip, incl. empty bottle, replaceable IMP 24 series stainless steel pump, easy pump replacement through front removal, autoclavable and dishwasher-safe Dimensions: W 82 x H 245 x D 160 mm
... Pcs.	ingo-man® plus IMP T P/24 luminous red Art. No. 1418094 Soap-/disinfectant dispenser, 1000 ml, suitable for standard disposable bottles, refillable containers and hygiene packages, luminous red powder-coated aluminium housing, short stainless steel operating lever, with identification clip, incl. empty bottle, replaceable IMP 24 series stainless steel pump, easy pump replacement through front removal, autoclavable and dishwasher-safe Dimensions: W 92 x H 290 x D 160 mm	... Pcs.	ingo-man® plus IMP T P/24 luminous bright orange Art. No. 1418096 Soap-/disinfectant dispenser, 1000 ml, suitable for standard disposable bottles, refillable containers and hygiene packages, luminous bright orange powder-coated aluminium housing, short stainless steel operating lever, with identification clip, incl. empty bottle, replaceable IMP 24 series stainless steel pump, easy pump replacement through front removal, , autoclavable and dishwasher-safe Dimensions: W 92 x H 290 x D 160 mm
... Pcs.	ingo-man® plus IMP E P/25 luminous yellow Art. No. 1418092 Soap-/disinfectant dispenser, 500 ml, suitable for standard disposable bottles, refillable containers and hygiene packages, luminous yellow powder-coated aluminium housing, short stainless steel operating lever, with identification clip, incl. empty bottle, replaceable IMP 24 series stainless steel pump, easy pump replacement through front removal, autoclavable and dishwasher-safe Dimensions: W 82 x H 245 x D 160 mm	Product: Manufacturer:	ingo-man® plus OPHARDT HYGIENE-TECHNIK GmbH + Co. KG
... Pcs.	ingo-man® plus IMP T P/25 luminous yellow Art. No. 1418095 Soap-/disinfectant dispenser, 1000 ml, suitable for standard disposable bottles, refillable containers and hygiene packages, luminous yellow powder-coated aluminium housing, short stainless steel operating lever, with identification clip, incl. empty bottle, replaceable IMP 24 series stainless steel pump, easy pump replacement through front removal, autoclavable and dishwasher-safe Dimensions: W 92 x H 290 x D 160 mm		